



VR843E TELEHANDLER

KEY FEATURES

- 8,000 lbs (3,632 kg) Maximum Lift Capacity
- 43'1" (13.1 m) Maximum Lift Height
- 6,000 lbs (2,722 kg) Capacity @ Maximum Lift Height
- 28'2" (8.6 m) Maximum Forward Reach
- 1,900 lbs (862 kg) Capacity @ Maximum Reach
- Cummins Tier 4i QSB3.3, Turbocharged, 110HP @ 2400 rpm
- Powershift, 3 Speed Transmission
- 3 Mode Steering
- 48" floating pin carriage with 48" pallet forks

STANDARD FEATURES

- Standard quick attach carriage mount system
- Dual lift cylinders with cushioning effect
- See through open "A" frame high pivot boom mount design
- Rear window w/wiper
- Side window
- Single multifunction pilot operated joystick control
- Instrumentation: hourmeter and fuel gauge, indicator lights for transmission oil temperature, battery condition, engine coolant pressure and engine oil pressure
- Park brake test button
- 12V DC electrical system with 12V power outlet in cab
- Lockable in cab storage box
- Mid-mount in line engine design
- Lockable sliding engine cover allows access with boom fully stowed
- 40 (151L) gallon steel hydraulic tank with lockable cap
- 35 (133L) gallon steel fuel tank with lockable cap
- Mirrors, right and left side
- Remote grease fittings for axle trunnion mount lubrication
- Easy to remove steel component and access covers
- 12 months/2000 hour warranty (5 years on structure)
- Telematics ready

VR843E TELEHANDLER

8,000 lbs (3,629 kg) capacity 43' 1" (13.13 m) maximum lift height

SPECIFICATIONS	VR843E
Maximum Lift Capacity	8,000 lbs (3,629 kg)
Maximum Lift Height	43' 1" (13.13 m)
Rated Lift Capacity @ Maximum Height	6,000 lbs (2,722 kg)
Maximum Forward Reach	28' 2" (8.59 m)
Rated Lift Capacity @ Maximum Reach	1,900 lbs (862 kg)
O/A Length - Less Forks	21' (6.4 m)
Overall Height - Stowed	7' 11" (2.41 m)
Overall Width	8' 6" (2.59 m)
Ground Clearance	14.75" (38 cm)
Turning Radius - Outside	12' 3" (7.73 m)
Operating Weight	22,158 lbs (10,072 kg)
Engine	110 hp Cummins Tier 4i QSB3.3
Max Travel Speed - Forward	19.5 mph (31.4 kmh)
Transmission	Dana powershift, 3 speeds forward and reverse
Axles	Dana steerable outboard planetary
Service Brakes	4 wheel wet disc
Parking Brakes	SAHR on rear axle
Steering	3 mode (2 wheel, 4 wheel, crab)
Tires	13 x 24 16PR grip lug

OPTIONAL EQUIPMENT

- Single Auxiliary Hydraulics
- Stabilizers
- Road Lighting Package (includes 1 headlight, 2 front and 1 rear work lights, boom lights, and turn signals)
- Work and Boom Lighting Package (includes 2 front and 1 rear work lights, and 2 boom lights)
- Rotating Beacon
- All Weather Cab (w/wipers, heater & defroster, fan, tinted glass, sliding side window and suspension seat)
- Cab Air Conditioning
- Open Operator Station Upgrade (w/vandal cover and full suspension seat)
- Block Heater
- Hydraulic Test Ports
- Four Wheel Fender Set
- Pintle Hitch
- Reserve Brake
- Positive Air Shut-off Valve
- Yoke Mounted Lifting Hook
- Non Destructive Testing

ATTACHMENTS

- Various Carriage (48"-72") and Fork Sizes
- 2' High Capacity Jib Boom
- 12' Truss Boom
- 1.75 yd³ 95 in. wide Bucket

TIRE OPTIONS

- Foam Filled Rough Terrain Tires
- Hard Surface Tread Tires
- Foam Filled Hard Surface Tread Tires
- Solid Rubber Tires

IMPORTANT

- Machine design complies with ANSI/ITSDF B56.6-2005 stability requirements for rough terrain forklifts.
- Rated capacities shown are with machine on firm level ground, steered straight with frame level and on properly inflated tires.
- Read boom angle and boom extension, then determine allowable load from chart.
- Do not exceed rated loads as dangerous and unstable machine conditions will result.
- Always travel with boom retracted in the lowest possible position.

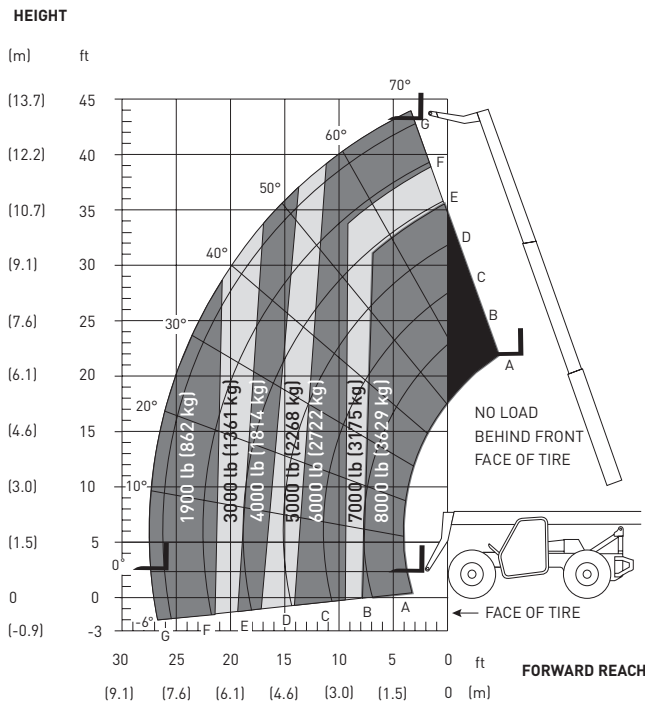

Skyjack Head Office

55 Campbell Rd. Guelph, ON Canada N1H 1B9
 Sales Inquiries: 1-877-755-4387 (1-877-SJLIFTS)
 Main Switchboard: 1-800-265-2738
 Phone: 519-837-0888
 Fax: 519-837-8104
 Email: skyjack@skyjack.com
 www.skyjack.com

